

TECHNICAL MANUAL

ULTRASURE Non-combustible Prefinished Solid Aluminium Panel

- 1. Introduction**
- 2. Quality Control**
- 3. Physical Properties**
- 4. Fire Performance**
- 5. Coating Performance**
- 6. Fabrication**
- 7. Installation**
- 8. Miscellaneous**

1.1 About This Manual:

This manual has been developed to effectively assist fabricators and contractors to work with ULTRASURE. Due to the uncontrollable conditions onsite and different methods of job scope, as well as the variable skills and judgment of installers and the quality of equipment, tools, etc, the suggestions and recommendations contained in this manual are provided without warranty. The information and recommendations herein are believed to be correct at time of publishing.

BLUECHIP reserves the right to revise the contents of this manual without prior notice. Any construction or use of the product must be in accordance with all local zoning and/or building codes and in accordance with the current NCC at the time of use. Except as contained in a written warranty certificate, the supplier does not provide any other warranty, either express or implied, and shall not be liable for any damages, including consequential damages.

1.2 Company Background:

Founded in 2003 by five brothers, BLUECHIP has grown every year since to become one of Australia's leading suppliers of architectural building envelopes. BLUECHIP's product range covers the complete system from the structure out including all types of cladding materials, composite decking, sub-framing, insulation, waterproofing and fixings.

Based in Perth WA and with many years combined experience, BLUECHIP has supplied more than 3,000,000m² of materials to Australian projects since 2003. Our commitment to innovation and ongoing investment in R&D ensures BLUECHIP will continue to lead the market with BCA/NCC compliant facade solutions in the years ahead.

For architects and consultants, BLUECHIP's wide range of different materials and 'complete-system' approach enables the creation of inspiring high-performance facades. For builders and contractors, BLUECHIP's large local stock, well established supply chains and genuine appreciation for our clients means you can trust us to deliver as promised every time.

1.3 Company Details:

Company: Blue Chip Group Pty Ltd
ABN: 98 162 282 064
Address: 6 Ashby Close, Forrestfield WA 6058
Phone: 08 9451 2344
Fax: 08 9451 8983
Email: sales@bluechipgroup.net.au

1.4 Product Description:

Designed to complement our ULTRACORE non-combustible core panel, ULTRASURE completes our range of BCA compliant, Deemed-to-Satisfy non-combustible aluminium cladding solutions. The 3mm solid aluminium cassette panel system offers very high impact resistance and can be curved, rolled or perforated. ULTRASURE features the same factory applied PVDF coating system widely renowned for its superior durability and finish quality. Unlike traditional powder coating, prefinished PVDF panels do not require fabrication prior to coating greatly reducing lead-times and costs.

Finished Before Fabrication

Unlike traditional powder coated panels, ULTRASURE is prefinished with factory applied PVDF coating and a protective peel-off film before fabrication into cassette panels providing many practical advantages.

AS 1530.1 Non-Combustible

ULTRASURE is one of the few aluminium cassette panel solutions that is Deemed-to-Satisfy non-combustible when tested to AS 1530.1 and AS 1530.3 as per the requirements of NCC 2019 Clause C1.9(e)(v).

NCC 2019 Compliance

ULTRASURE solid aluminium panel is Deemed-to-Satisfy non-combustible as per NCC 2019 Clause C1.9(e)(v) making it compliant for use as external cladding on any project of types A, B & C construction.

Unlimited Custom Colours

ULTRASURE 3mm solid aluminium panel utilises the same PVDF coating as ULTRABOND FR and ULTRACORE so it is available in the same extensive colour range and custom colours. MOQ's apply.

Concealed Fixings

ULTRASURE 3mm solid aluminium panel is the same in principle to fabricate and install as traditional aluminium composite panels by CNC routing panels into the concealed fix z-angle cassette system.

PVDF Paint System

ULTRASURE 3mm aluminium panel only uses the highly recognised PVDF KYNAR 500 or FEVE paints known for their high durability, providing the optimum resistance to weather and industrial pollution.

Curve, Roll or Perforate

The ULTRASURE 3mm aluminium panel offers excellent design versatility as it can be made into panels of almost any shape and size as well as being suitable for curved panels, rolling and perforating.

Manufacturer's Warranty

ULTRASURE 3mm aluminium panel coating system has a long track record of consistency, reliability and quality allowing us to offer up to 15 year's warranty when installed by a licensed installer.

1.5 More Information:

www.bluechipgroup.net.au/facade-cladding-perth/prefinished-solid-aluminium-panel-perth.html

2.1 Manufacturing Quality:

A dedication to the total fulfillment of our client's expectations is reflected by a complete quality control system, beginning at the point of specification and continuing through to delivery of the guaranteed products. All activities are carried out in a manner which:

- Uses the framework of ISO9000 Quality Standards to verify the quality of our systems
- Ensures that our products and services are of the highest standards
- Creates continuous improvements to our product and processes through the application of the best quality practices.

2.2 Acceptable Tolerances:

Panel Width:	+/- 3.0mm
Panel Length:	+/- 5.0mm
Thickness:	+/- 2.0%
Bow Allowed:	<0.5%
Squareness:	<5.0mm
Surface Defects:	In accordance with AAMA 2605-05

2.3 Product Warranty:

The standard product warranty is 10 years, with longer warranties available on a project specific basis. The supplier excludes all warranties in relation to the goods except for those provided in a Warranty Certificate provided to the Customer by the supplier in relation to the Goods.

A project specific full-system warranty may be available if the product is supplied with all recommended system components and fabricated and installed by a licensed installer accredited and approved by BLUECHIP in writing.

3.1 Panel Composition:

1. Peel-off Protective Film
2. PVDF Coil Coating System
3. 3mm Solid Aluminium Panel

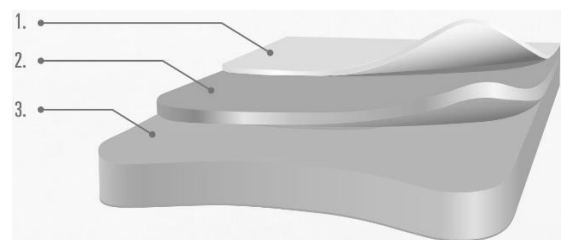

3.2 Recommended Panel Sizes:

When v-grooving and cassette-fixing ULTRASURE or any other similar solid aluminium products it is very important to consider the high expansion & contraction rates of solid aluminium due to its high thermal conductivity. Panel sizes should be limited as required for any given application, considering the minimum & maximum temperatures the panel will be exposed to, the colour of the panel and the façade orientation to ensure the panels thermal movement will not exceed the systems capabilities and to ensure ongoing durability and waterproofing;

Special consideration should be given to the following;

- Overall panel sizes to ensure thermal movement will not exceed joint sealant capabilities
- Distance to joints either side of corner and parapet panels to avoid stress on the corner

3.3 Technical Data – Physical Properties:

ITEM	TEST STANDARD	UNIT	RESULT
Alloy Grade / Temper	Actual	-	3003 H14
Thickness	Actual	mm	3.0
Panel Weight	Actual	Kg/m ²	8.1
Rigidity	Actual	Hba	55
Elongation	Actual	%	2.9
Modulus of Elasticity	Actual	N/mm ²	72
Tensile Strength	Actual	N/mm ²	165
0.2% Proof Stress	Actual	N/mm ²	95
Yield Point	Actual	MPa	130
Melting Point	Actual	°C	640
Thermal Conductivity	ASTM C-518	W/mK	>180
Thermal Expansion	Actual	mm/m/°C	0.025

3.4 Benefits of 3000 Series Aluminium:

The standard aluminium grade used for ULTRASURE coil-coated panels is 3003 H14 which is globally recognised as the ideal alloy & temper for architectural façade panel applications with excellent performance across all key considerations including at high temperature.

Benefits of 3003 aluminium for PVDF coil-coated architectural panels include;

- Manganese alloy with no magnesium content
- No risk of stress cracks caused by sensitization as is the case with magnesium alloys
- Higher melting point = less debris & greater fire safety
- Lower thermal conductivity = less heat transfer into the building for section J compliance
- Excellent corrosion resistance
- Superior mechanical strength
- Increased workability for easier v-grooving

4.1 Deemed-to Satisfy Non-combustible:

ULTRASURE is deemed-to-satisfy non-combustible as per the requirements of the NCC 2019, clause C1.9(e)(v) for use on any building of types A, B & C construction, classes 2-9.

4.2 Technical Data – Fire Performance:

ITEM	TEST STANDARD	UNIT	RESULT
Non-combustible	AS 1530.1	CSIRO	Pass
Non-combustible (DTS)	NCC C1.9(e)(v)	CSIRO	Pass
Ignitability Index	AS 1530.3	CSIRO	0
Spread of Flame Index	AS 1530.3	CSIRO	0
Heat Evolved Index	AS 1530.3	CSIRO	0
Smoke Developed Index	AS 1530.3	CSIRO	1
Fire Behaviour	EN 13501-1	Intertek	A1
Smoke Production	EN 13501-1	Intertek	s1
Flaming Droplets	EN 13501-1	Intertek	d0

5.1 Paint Systems:

ULTRASURE panels use only PVDF Kynar 500 or FEVE fluoropolymer-based paint systems applied using continuous coil coating. These paint systems are known for their high durability and optimum resistance to weather and industrial pollution. More than 40 years of use globally confirms the superior chemical and physical properties of fluoropolymer coatings.

ULTRASURE coatings are applied in accordance with AAMA 2605-05, the internationally recognised paint standard for architecturally finished aluminium.

5.2 Technical Data – PVDF Kynar 500 Coating Properties:

ITEM	TEST STANDARD	UNIT	RESULT
Aluminium Substrate	ASTM D1005	-	Pass
Coating Flexibility	ASTM D4145	2T	Pass
Dry Film Thickness <ul style="list-style-type: none"> ▪ Primer Coating ▪ Coloured Coating ▪ Clear Coating (If applicable) 	ASTM D1400 ASTM D1400 ASTM D1400	Mil Mil Mil	0.2-0.3 0.7-0.8 0.3-0.4
Colour Difference	ASTM 2244	4000hrs	DE<5
Gloss Retention	ASTM 2244	4000hrs	85%
Chalking Resistance	ASTM 2244	4000hrs	<8
Pencil Hardness	ASTM D3363	-	HB
Dry Film Adhesion	Actual	38°C, 24hrs	Pass
Wet Film Adhesion	Actual	100°C, 24hrs	Pass
Reverse Impact Adhesion	ASTM D3359	1/16	Pass
Bending / Gardener Impact	ASTM D3281	-	Pass
Salt Resistance <ul style="list-style-type: none"> ▪ 5% Salt Spray @ 95°F ▪ Gloss Reduction ▪ Colour Change ▪ Chalk Resistance 	ASTM B117 ASTM D523 ASTM 2244 ASTM 4214	4000hrs 5000hrs 5000hrs 5000hrs	Pass 0.8% DE=0.68 Pass
Humidity Resistance <ul style="list-style-type: none"> ▪ 100% RH @ 95°F ▪ Gloss Reduction ▪ Colour Change ▪ Chalk Resistance 	ASTM B117 ASTM D523 ASTM 2244 ASTM 4214	4000hrs 5000hrs 5000hrs 5000hrs	Pass 0% DE=0.52 Pass
Weather Resistance <ul style="list-style-type: none"> ▪ Exterior Exposure @ 45° ▪ Gloss Reduction ▪ Colour Change ▪ Chalk Resistance 	South Florida ASTM D523 ASTM 2244 ASTM 4214	10 years 5000hrs 5000hrs 5000hrs	Pass 6.2% DE=0.27 Pass
Chemical Resistance <ul style="list-style-type: none"> ▪ Mortar Test ▪ Gloss Reduction ▪ Colour Change 	ASTM C207 ASTM D523 ASTM 2244	24hrs 16hrs 16hrs	Pass 6.2% DE=0
Solvent Resistance - MEK	ASTM 2794	Double Rub	Pass
Acid Resistance – 10% H ₂ SO ₄	ASTM 1308	7 days	Pass
Alkali Resistance – 10% NaOH	ASTM 1308	7 days	Pass
Detergent Resistance – 3%	ASTM D2248	72hrs	Pass

6.1 V-grooving:

V-grooving ULTRASURE to fabricate cassette panels is similar to v-grooving traditional ACP such as ULTRABOND FR however it is generally much slower. Traditionally ACP with a solid core and 0.5mm face skin is grooved to leave approximately 0.3mm of core material remaining with total material remaining of 0.8mm (0.5mm face skin + 0.3mm of core).

The recommended overall depth for v-grooving ULTRACORE is the same or slightly less than traditional ACP to leave between 0.8-0.9mm of total material remaining. In any case, the material remaining at the base of the v-groove should never be less than 0.7mm.

Like standard ACP, a 90-degree v-groove router bit should be used with a minimum 3.0mm flat at the base of the v-groove. As with any other solid aluminium panels, it is not possible to visually check the depth of the v-groove by looking to see how much core is remaining as is common practice with traditional ACP and ULTRACORE panels.

Accordingly, we only recommend v-grooving ULTRASURE panels on precision flat-bed CNC routers with maximum +/-0.1mm accuracy and operated by an experienced fabricator to ensure v-groove depth does not exceed 0.7mm under any circumstance.

MACHINE	TOOLING	DEPTH	M/Min
CNC Router (Recommended)	90° with a flat 3.0mm wide base	Min 0.7mm of material remaining	5-10
Wall Saw or Portable Saw	Not allowed	Not allowed	Not allowed

6.2 Cutting:

ULTRASURE can be cut with identical tooling to that used for ULTRABOND FR and similar ACP's. For CNC router machines, an up-spiral cutter is recommended to assist with swarf removal. There is no coolant required on the cutter or v-groove tooling when fabricating ULTRASURE panels although methylated spirits may be used to achieve maximum speeds.

6.3 Rolling:

ULTRASURE can be rolled to form a curved panel the same as traditional ACP's. Rolling machines with 2 sets of rollers are recommended for best results and rollers should be perfectly clean and free from swarf which may damage the panels. It is recommended to conduct testing to ensure satisfaction with the results before commencing production.

6.4 Recommended Panel Sizes:

When v-grooving and cassette-fixing ULTRASURE or any other similar solid aluminium products it is very important to consider the high expansion & contraction rates of solid aluminium due to its high thermal conductivity. Panel sizes should be limited as required for any given application, considering the minimum & maximum temperatures the panel will be exposed to, the colour of the panel and the façade orientation to ensure the panels thermal movement will not exceed the systems capabilities and to ensure ongoing durability and waterproofing;

Special consideration should be given to the following;

- Overall panel sizes to ensure thermal movement will not exceed joint sealant capabilities
- Distance to joints either side of corner and parapet panels to avoid stress on the corner

7.1 Installation:

Mechanical cassette-fix installation is the recommended installation system for ULTRASURE cladding using the well-proven v-groove 'route & return' fabrication method with offset aluminium z-angles as per the below detail. It is also acceptable to install ULTRASURE in a glazing suite for curtain wall application or face-fixed. Tape-fix installation is not recommended.

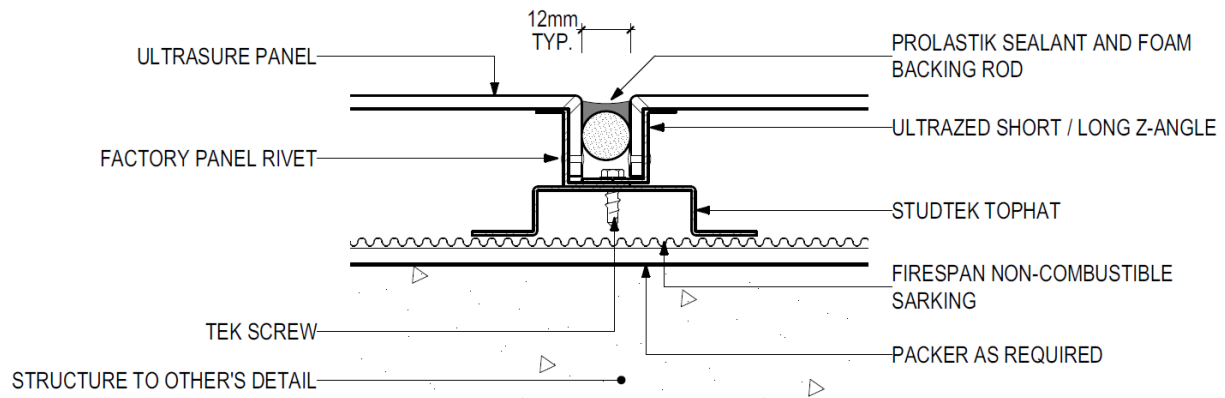

ULTRASURE installation details are available in PDF and CAD on request. The ULTRASURE installation details are provided for conceptual purposes only. These are not the only methods that can be used to attach ULTRASURE, nor can they be used generically without consideration for each individual application. Good design engineering may preclude the choice of details used.

7.2 Acceptable System Components:

Sarking:

Shall be FIRESPAN deemed-to-satisfy non-combustible sarking tested by a NATA accredited laboratory to AS 1530.1. Install and tape in accordance with AS 4200.2 to all cladding areas.

Sub-framing System:

The sub-framing system to be attached to the main structure in a manner to ensure all applied loadings to the cladding is transferred back to the main structure. Size and spacing of top hat members shall be determined according to applied loads and deflection limitations. Top-hat centres shall be maximum 600mm or installed in a matrix layout to provide full perimeter support to each panel as required to adequately support the cladding system.

- STUDTEK Facade Framing, 08 9451 2344, sales@bluechipgroup.net.au.

STUDTEK Zinalume Framing is recommended and it is cold-formed according to AS/NZS:4600 from Zinalume G300 steel which is continuous hot-dipped aluminium/zinc alloy-coated structural steel as per AS:1397.

Aluminium Z-angle Profiles:

Shall be ULTRAZED extruded aluminium alloy AA 6063-T5 supplied by Blue Chip Group Pty Ltd. The long z-angle shall be powder-coated to avoid bimetallic corrosion with the top-hats.

Panel Joint Sealant:

Panel joints to be sealed with PROLASTIK matt silicone sealant supplied by Blue Chip Group Pty Ltd and installed over open cell foam backing rod to manufacturer's specifications.

7.3 General Installation Guidelines:

- All sheets should be installed in the same direction as marked on the protective film to prevent possible finish variation.
- As minor colour variation can occur between production lots, it is recommended to place total requirements for a project in one order to ensure colour consistency.
- Where aluminium materials come into contact with dissimilar metals, a proper insulator, protective coating or caulking tape should be applied to insulate between dissimilar materials in order to avoid bimetallic corrosion and/or electrolytic action.
- The cassette fixed panel joints should not be caulked before the protective film is removed.

7.4 Recommended Panel Sizes:

Panel sizes should be limited as required for any given application, considering the minimum & maximum temperatures the panel will be exposed to, the colour of the panel and the façade orientation to ensure the panels thermal movement will not exceed the systems capabilities and to ensure ongoing durability and waterproofing;

Special consideration should be given to the following;

- Overall panel sizes to ensure thermal movement will not exceed joint sealant capabilities
- Distance to joints either side of corner and parapet panels to avoid stress on the corner

8.1 Protective Film:

- Make sure no damage will occur to the panel prior to the removal of the protective film.
- Remove the protective film within 45 days of installation to avoid glue residue on panel surface due to weathering.
- Do not apply PVC tapes, polyurethane sealant or silicone sealant onto ULTRASURE protective film. The plasticiser contained in these materials can penetrate the protective film and cause a gloss change in the coating.
- Do not apply spray paint or permanent marker to the film as the colour may penetrate the film and affect the surface coating of the panel.

8.2 Storage & Handling:

- Considerable care should be taken in the handling of ULTRASURE as the panels are sensitive to impact particularly from small hard objects such as stones which can dent the aluminium cover sheet
- A minimum of two people should be used when moving and stacking large sheets to avoid surface damage. Sliding panels should be avoided unless they are back-to-back.
- Pallets of ULTRASURE should be stored horizontally in a cool and dry area where temperature is stable with adequate support to prevent sagging.
- Stacked pallets should be identically sized and not more than three (3) pallets high.

8.3 Cleaning & Maintenance:

- The cladding shall be cleaned and maintained in accordance with AAMA 609 & 610-09 as required to avoid any accumulation of surface contaminants and to maintain the desired performance and appearance.