

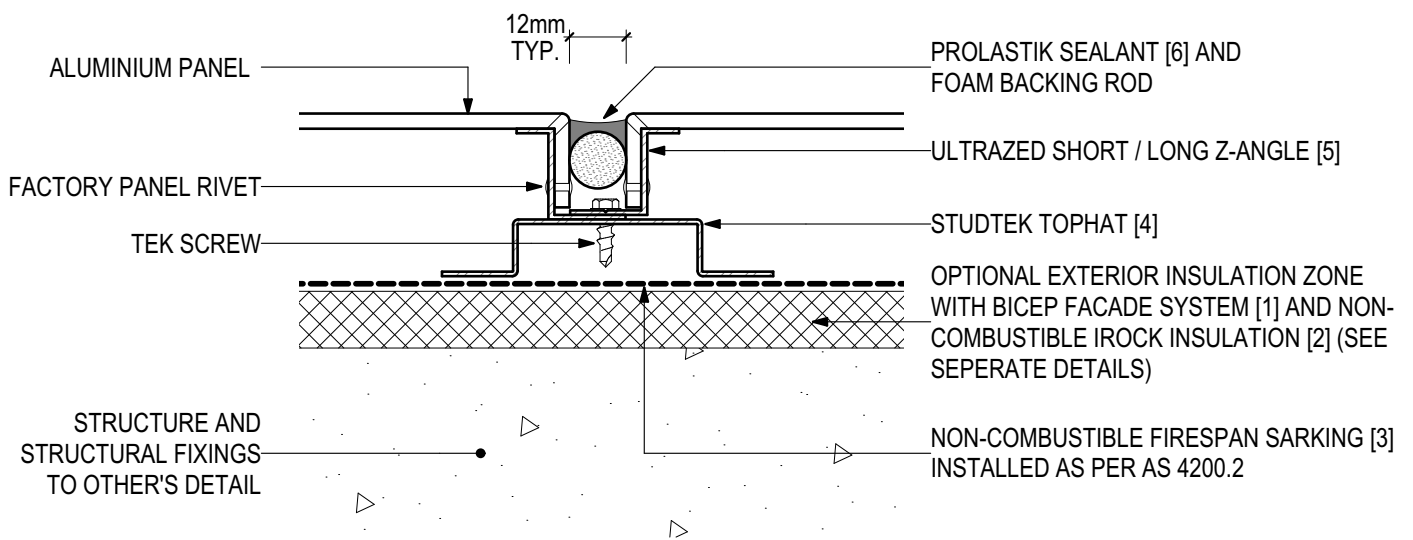

D.01 - TYPICAL FIXING DETAIL (SCALE 1:2)

ULTRAZED Aluminium Z-angle Mechanical Cassette Fix Detail (V0922)



SYSTEM COMPONENTS

BICEP FACADE SYSTEM [1]



IROCK INSULATION [2]



FIRESAN SARKING [3]



STUDEK TOPHAT [4]



ULTRAZED Z-ANGLES [5]



PROLASTIK SEALANT [6]

