

# TRI MO TRIMOTERM



HORIZONTAL FAÇADE SYSTEM **TRIMOTERM FTV**

## TABLE OF CONTENTS

### **1 Technical Description of the Horizontal Façade System 1**

- 1.1 General 1
- 1.2 Panel Profile 1
- 1.3 Panel Composition 2
- 1.4 Technical Data 2
- 1.5 Coatings 2

### **2 Design procedure 3**

- 2.1 Panel Thickness Selection 3
- 2.2 Structural Design Data 3
- 2.3 Fixing Methods 3
- 2.4 Sealing 3

### **3 Recommendations for installation 4**

- 3.1 Removing Protective Foil 4
- 3.2 Elements Cutting 4
- 3.3 Lifting Methods 5

### **4 Installation Details 6**

- 4.1.1 Connection to the Main Beam 6
- 4.1.2 Corner Element Detail 7
- 4.2 Fixing a Horizontal Façade to a Steel Structure 8
  - 4.2.1 Installation of a Load-bearing Steel Structure 8
  - 4.2.2 Fixing a Horizontal Façade to a Steel Structure using HF102 Aluminium Fixing Profile 8
  - 4.2.3 Temporary Fixing 9
  - 4.2.4 Assembly of Aluminium Profiles 11
- 4.3 Fixing a Horizontal Façade to a Concrete Structure 11
  - 4.3.1 Fixing a Horizontal Façade by a Levelling Profile 11
  - 4.3.2 Fixing a Horizontal Façade using Adjustable Substructure system HMP 2 12

Descriptions of details, and other information in this document, are only provided to illustrate the system(s) of Trimoterm cladding products and applications. Each user of such information is fully responsible for the incorporation of this advisory information in its design.

Trimo assumes no liability whatsoever for any damages incurred by you resulting from errors in or omissions from the information included herein.

Care has been taken to ensure that information contained in the document are accurate, but Trimo, including its subsidiaries, does not accept responsibility or liability for errors in information.

# 1. Technical Description of the Horizontal Façade System

## 1.1 General

The basic horizontal façade system consists of Trimoterm FTV panels of standard modular widths 1000 and 1200 mm.

The range of applications for the horizontal joint façade system is extremely wide. They are suitable for business, commercial, leisure, trade and industrial buildings. The horizontal façade system has excellent technical properties, a long life span and allows creative freedom in building envelope design.

The system of Trimoterm fireproof panels ensures high fire resistance, excellent thermal and sound insulation. The panels are used primarily as a facade, partition walls, fire walls and ceilings, or even as a back up panels for variety of rainscreen façade systems.

## 1.2 Panel Profile

Fig. 1: Trimoterm FTV façade panels

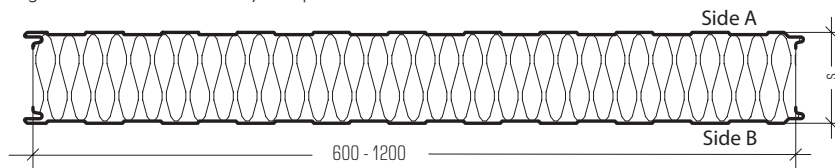
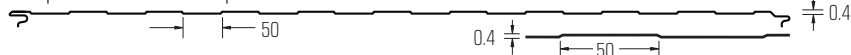

Fig. 1a: Possible forms of Trimoterm FTV 1000 façade panels

External Profile Types:

S - profile (standard profile)



V - profile (v)



V - profile (v2)

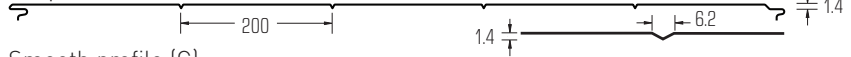

Smooth profile (G)

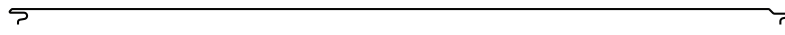

Smooth profile (g)



Micro-lined profile (m)

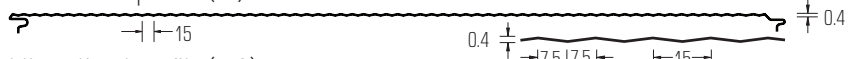

Micro-lined profile (m3)



Multi vario profile (X01)



Internal Profile Types:

S - profile (standard profile)

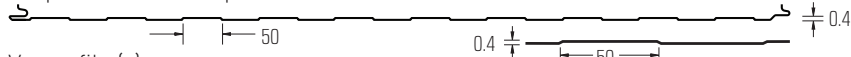

V - profile (v)

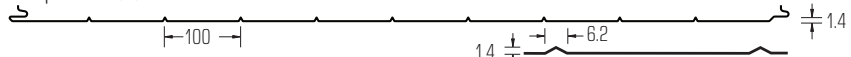

V - profile (v2)

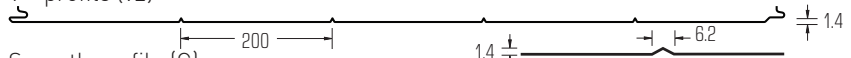

Smooth profile (G)

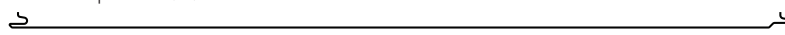

Smooth profile (g)

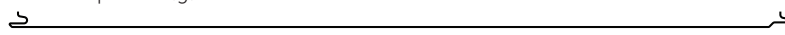

Micro-lined profile (m2)



Fig. 1b: Possible forms of Trimoterm FTV 1200 façade panels

External Profile Types:

S - profile (standard profile)

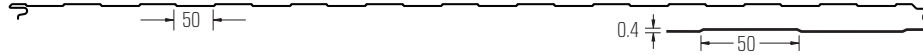

V - profile (v)

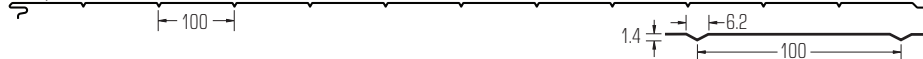

V - profile (v2)



V - profile (v6)

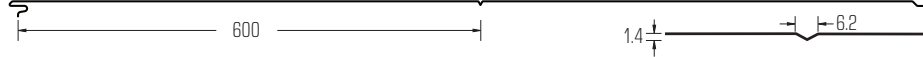

Smooth profile (G)

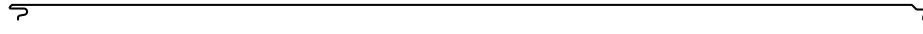

Smooth profile (g)

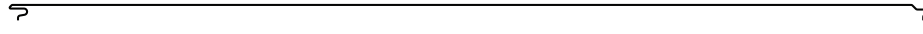

Micro-lined profile (m)

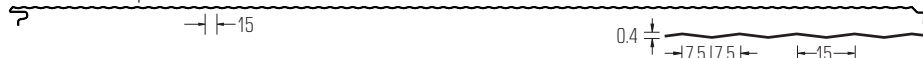

Micro-lined profile (m3)



Multi vario profile (X01)



Internal Profile Types:

S - profile (standard profile)

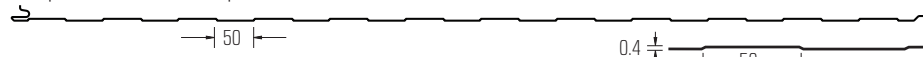

V - profile (v)

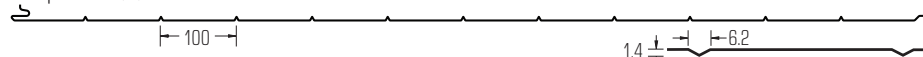

V - profile (v2)

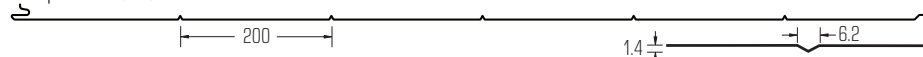

V - profile (v6)

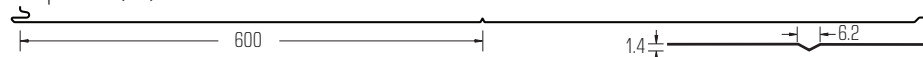

Smooth profile (G)

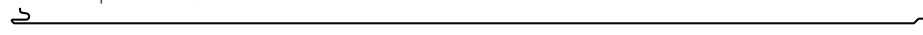

Smooth profile (g)

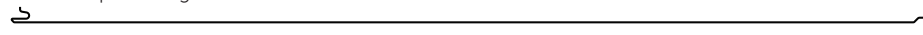

Micro-lined profile (m2)



Profile Type	A	B
S - profile (s)	•	•
V - profile (v, v2, v6)	•	•
Smooth profile (G, g)	•	•
Micro-lined profile (m, m3)	•	
Micro-lined profile (m2)		•
Multi vario (X)	•	

Side A is usually the external side of a panel.

Steel sheet thickness for profile v2, v6, G-gladio and Multi vario (except X01 profile) is 0.7 mm.

Note: Complete panel range can be found in Trimoterm brochure Trimoterm Fire proof - Product Range.

## 1.3 Panels Composition

Trimoterm FTV fireproof panels consist of two shallow profiled, coated sheet faces in thicknesses of 0.5 mm to 0.7 mm. The steel sheet is bonded to the panel core made of non-combustible mineral wool lamellas of class A1 (EN 13501-1). All three layers make a solid panel in a thickness of 50 - 240 mm. Standard width of the panels are 1000 and 1200 mm. Non standard panel width of 600 - 1200 mm can be made by a special request. A protective PVC film is applied to the panel surface to protect it during production handling and transport. Panels can be manufactured up to 14 m length.

## 1.4 Technical Data

Table 1: Technical data of Trimoterm FTV 1000 and FTV 1200 façade panels

Technical data FTV		FTV 50	FTV 60	FTV 80	FTV 100	FTV 120	FTV 133	FTV 150	FTV 172	FTV 200	FTV 240
Panel thickness [mm]		50	60	80	100	120	133	150	172	200	240
Weight FTV 1000 [kg/m <sup>2</sup> ]	Fe 0,6/Fe 0,6	16,3	17,5	19,9	22,3	24,7	26,3	28,3	31,0	34,3	39,1
Weight FTV 1200 [kg/m <sup>2</sup> ]	Fe 0,6/Fe 0,6	16,1	17,3	19,7	22,1	24,5	26,1	28,1	30,8	34,1	38,9
Cover width [mm]		1000 and 1200									
Panel length [m]		up to 14									

Complete Technical data is available in Technical Specification data sheet.

## 1.5 Coatings

Steel sheet metal is hot galvanised (net 275 g/m<sup>2</sup>) in compliance with EN 10346, and additionally protected by organic coating in accordance with the coil-coating process (DIN EN 10169/1).

The following basic types of organic coatings protection are applied to steel sheet metal:

- based on SP polyester
- based on PVDF polyvinylidene fluoride
- based on PUR polyurethane
- based on PVC polyvinyl chloride, coating or film

Individual types of organic protection with the basic characteristics are presented in Table 2.

Table 2: Basic characteristics of an individual type of organic coating or protection

TYPE OF CORROSION PROTECTION	SP	SP	PVDF	PVDF+	PUR	PVC(P)	PVC+F
Corrosion classification [DIN 55928-8]	II	III	III	III	III	III	III
Total organic thickness (my) [EN 13523-1]	15	25	25	35	50	175-200	120-200
Temperature resistance (°C)	+70	+80	+110	+110	+110	+70	+70
UV resistance category [EN 13523-10]	—	Ruv3	Ruv4	Ruv4	Ruv4	Ruv2	—
Flexibility	••	••	•••	••••	••••	••••	••••
Staining resistance	••	•••	••••	••••	••••	••	••••

Note:

•••• suitable without reservations    ••• very suitable    •• suitable    • suitable with reservations/contact Trimoterm - unsuitable

Note: A detailed explanation of the coating, together with Instructions **for the use and maintenance can be found in the Technical instructions for the use and maintenance of Trimoterm products.**

## 2 Design procedure

### 2.1 Panel Thickness Selection

With respect to the client's or project requirements or in accordance with the legislation appropriate thickness of Trimoterm FTV panel shall be selected. Thickness has a direct influence on the load-bearing capacity of the panel, thermal insulation of the façade and heat stability of the structure.

### 2.2 Structural Design Data

Advised distances between supports are determined in relation to the selected panel thickness, loads and support widths. Panels are structurally weakened where windows, doors and other openings are installed. Exact Structural calculation is available by contacting Trimo Technical Support.

### 2.3 Fixing Methods

The fixing method is selected according to the structure type.

For steel structures:

- A distance profile is welded to a structure and the Trimoterm FTV panel is fixed to it by means of a specially made aluminium profile.
- Trimoterm FTV panel can be fixed directly to a flange if its thickness is not greater than 12 mm.

For concrete structures the following fixing methods are available for Trimoterm FTV panels:

- Fixing by a levelling profile for panels of 100 - 240 mm thickness.
- Fixing by a wide levelling profile for panels of 60 and 80 mm thickness.

Fig. 2: Load transfer of a weakened panel to adjacent panels

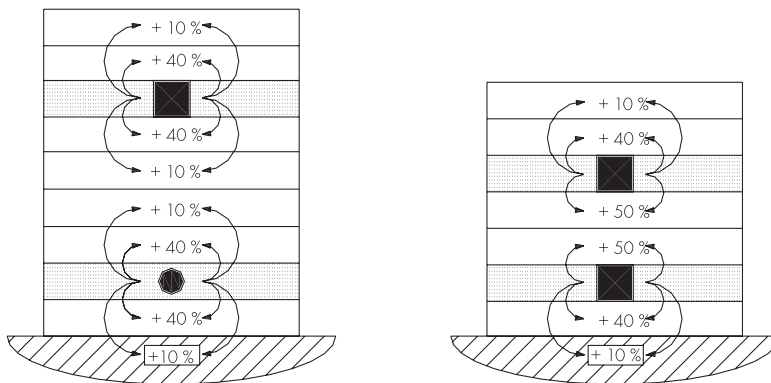

### 2.4 Sealing

Special care must be taken when designing sealing material. Local climatic conditions and internal environments must be taken into account. Trimoterm panels are typically factory applied with the required sealing gaskets. In extreme, demanding conditions it may also be essential to apply on site sealing mastic, within the joints.

### 3 Recommendations for installation

When erecting a horizontal façade panels must be correctly orientated, to allow water drainage (Fig. 3).

Fig. 3: Correct panel assembly on horizontal façades

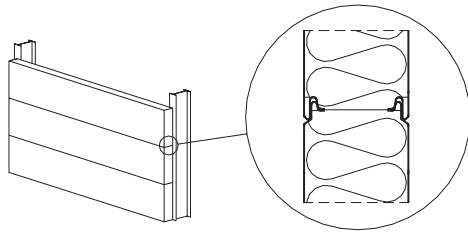

#### 3.1 Removing Protective Foil

A protective foil, for the protection of colour coated surfaces, against any possible damage caused during transport, handling and assembly, is applied to the external face of Trimoterm FTV panels. The foil must be removed from the internal face before the installation of an individual panel. The foil on the external side is removed directly before the completion of works; it should be removed during the installation where it is necessary, (e.g. in a longitudinal joint of two panels, under screws, flashing ...) (Fig. 4). If panels are to be stored for a long period of time, the foil should be removed after three months. If panels are to be stored in the open air, they should be protected against the sun, if not, the removal of the foil may be problematic.

Fig 4: Removal of the protective foil

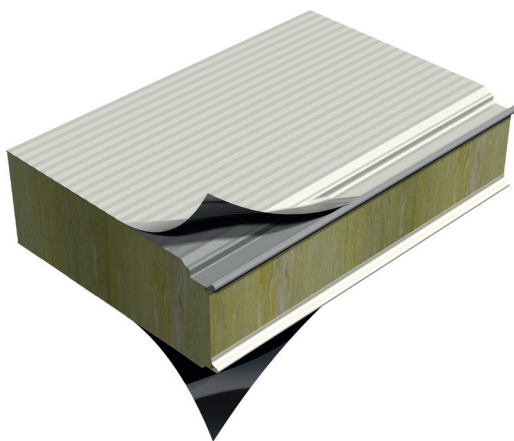

**NOTE:**

- If façade panels are stored for a long period of time the foil should be removed within three months at the latest.
- If the façade panels are to be stored in the open they should be protected against the sun; otherwise the complete removal of foil is no longer possible.
- During assembly the foil must be removed from all joints of the façade panel.

#### 3.2 Elements Cutting

When cutting panels during assembly, only special scissors, cutting tools and saws that do not heat the cutting edge to a high temperature, should be used (Fig. 5). High temperatures can damage the anti-corrosive protection, in the immediate surrounding area of a cut. Therefore, the use of any grinding machines is prohibited for such purposes! All small metal particles, that appear as a result of cutting and drilling should be immediately removed from the panel surface, but certainly when the daily work has been completed.

Marking and scratching with nails or similar sharp objects can damage the protective coating.

Fig. 5: Elements cutting is allowed with sheet metal shears and saws

Recommended use



Restricted use



### 3.3 Lifting Methods

It is suggested that special mechanical grippers are used for the assembly of a horizontal façade; these grippers can be placed in the longitudinal joint of Trimoterm FTV panel (Fig. 6). Two grippers are needed for one lift and they are delivered with panels, when specially ordered. Instructions for the use of grippers will be provided.

Fig.6: Gripper for the assembly of a horizontal façade

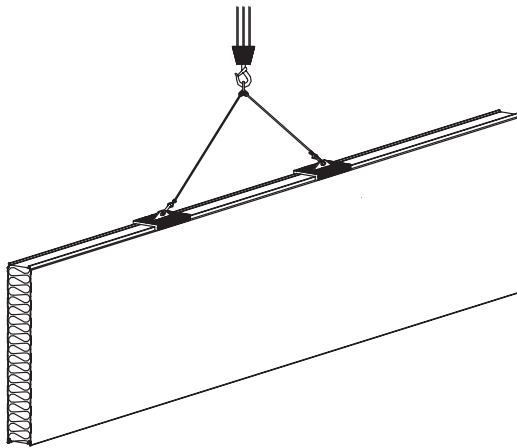



## 4 Installation Details

### 4.1.1 Connection to the Main Beam

Fig. 7: Connection of a horizontal façade to the main beam

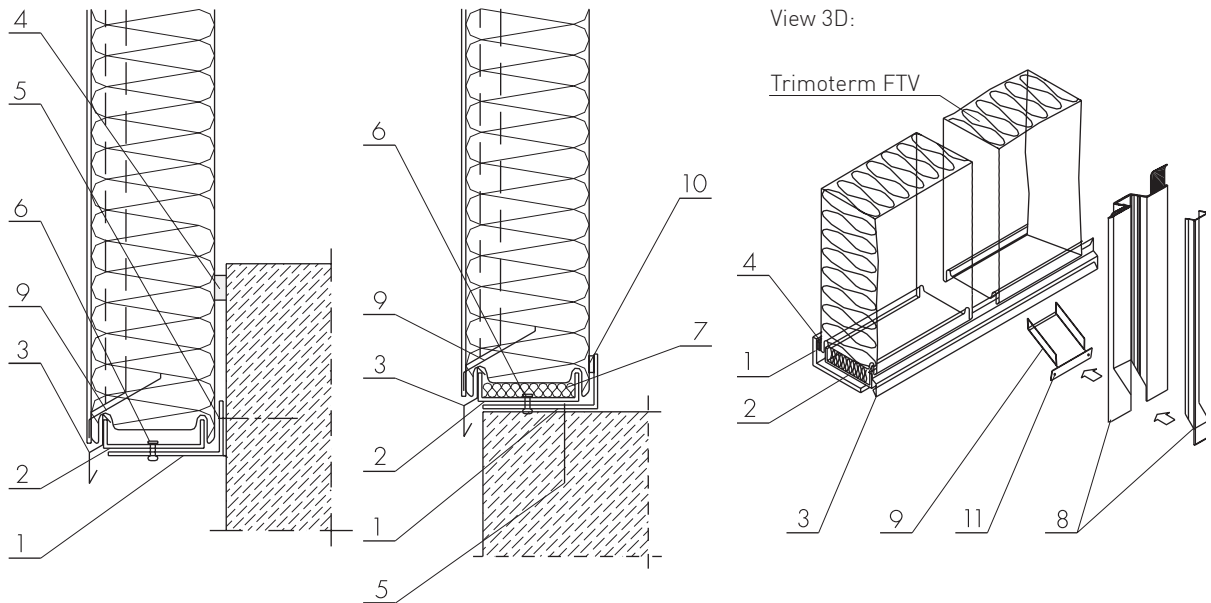

1. Support angle of the panel-closing element
2. Panel beam
3. Dripping edge of a panel
4. Sealing tape 30x20
5. Anchor bolt
6. Blind rivet
7. Thermal insulation
8. HF102 aluminium profile
9. Dripping edge of HF102 profile
10. Sealing tape 3x15
11. Blind rivet

The assembly begins in the final grid line of a building. Before the first panel is fixed, the precision of substructure geometry must be checked. Assembly sequence (Fig. 7):

- A support angle (Item 1) is to be fixed to the concrete main beam at a suitable height that serves as a horizontal levelling and riveting of the panel beam.
- A sealing tape is applied to a façade profile (Item 4).
- Before fixing of an individual panel, a Z profile is to be fixed for temporary mounting.
- The panel is to be placed correctly (distance of 40 mm) and fixed to a distance profile over Z profiles, by means of self-tapping 6.3x25 screws.
- The space between two panels is filled with soft mineral wool.
- Dripping edge of HF102 aluminium-fixing profile is fixed to the foundations of a horizontal façade extension.
- Cover flashing is fixed over screws; subsequent to a butyl sealing being applied.
- Front extension of the aluminium fixing profile is to be carried out by a connecting component and sealing (bonding) with a polyurethane adhesive (e.g. Sikaflex).
- The required number of screws per m<sup>2</sup> of the aluminium profile is determined by static calculations or in accordance with Section 2.3 of Trimo Technical Instructions.

## 4.1.2 Corner Element Detail

Fig. 8: Rounded-off corner detail

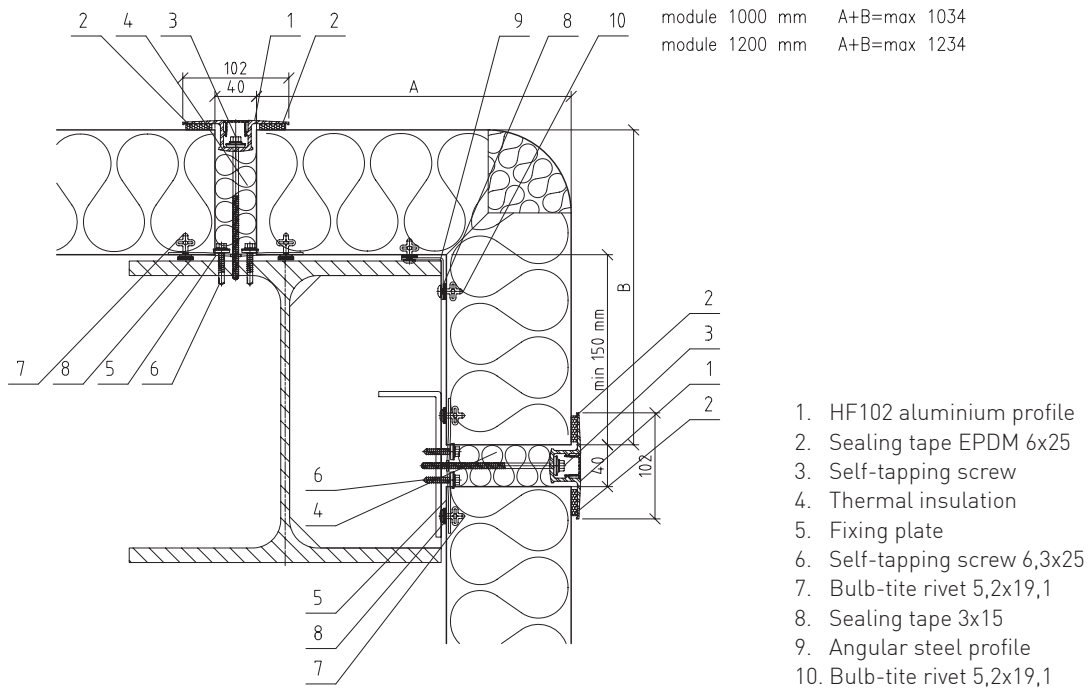
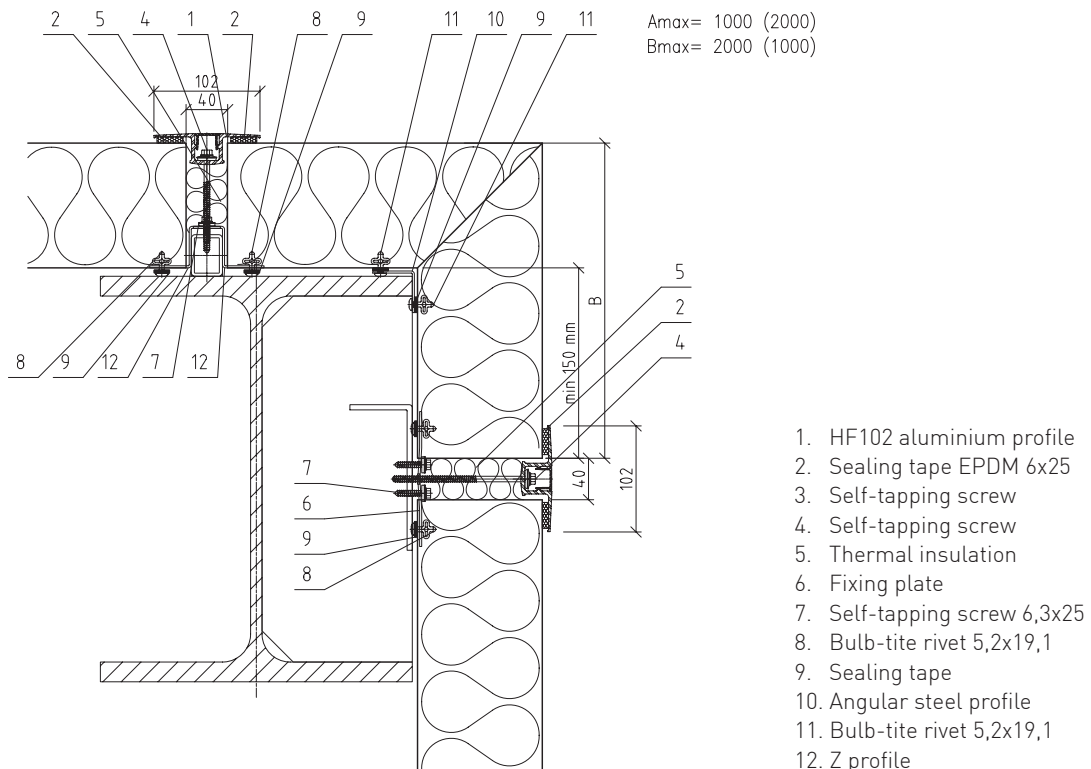

Fig. 9: Preformed sharp-edged corner



### Assembly sequence:

- Angular steel profile L profile for fixing the rounded corner element and façade panels is initially secured to the steel structure.
- Horizontal arrangement of the panels follows, which are laid horizontally and attached to it.
- Fixing plates, for temporary mounting, are riveted to the inner side of the vertical radius or horizontal, sharp-edged, corner panel (Fig. 8 and 9) and then this pre-assembled panel is fixed to the structure, using a self-tapping screw.
- The space between two panels is filled with soft mineral wool.
- The aluminium profile is fixed over screws to hold the panels in place.
- Before fixing the HF102 profile EPDM sealing tape 6x25 mm is applied.

## 4.2 Fixing a Horizontal Façade to a Steel Structure

A steel structure, to which panels are fixed, should comply with ENV 1090-1 or Trimo internal requirements.

### 4.2.1 Installation of a Load-bearing Steel Structure

Additionally, for classic steel structures, a distance profile (Fig. 10) should be welded to the basic steel structure, for a fast and simple installation of a horizontal façade. If the thickness of the load-bearing structure is  $b < 12$  mm, fitting of distance profiles is not required (Fig. 11) as it is possible to fix the panels directly.

Fig. 10: Distance profile



**WARNING:**

A box section 40x40x3 - St 37-2 is used as a distance profile for panel thickness exceeding 100 mm. Steel profile U 20x40x20x3 - St 37-2 is used as a distance profile for panel thickness 60 and 80 mm. A distance profile **IS NOT NECESSARY** when steel structure of **< 12 mm** is used (Fig. 11).

### 4.2.2 Fixing a Horizontal Façade to a Steel Structure using HF102 Aluminium Fxing Profile

Fig. 11: Fixing of a horizontal façade to a steel structure, depends on the thickness of substructure

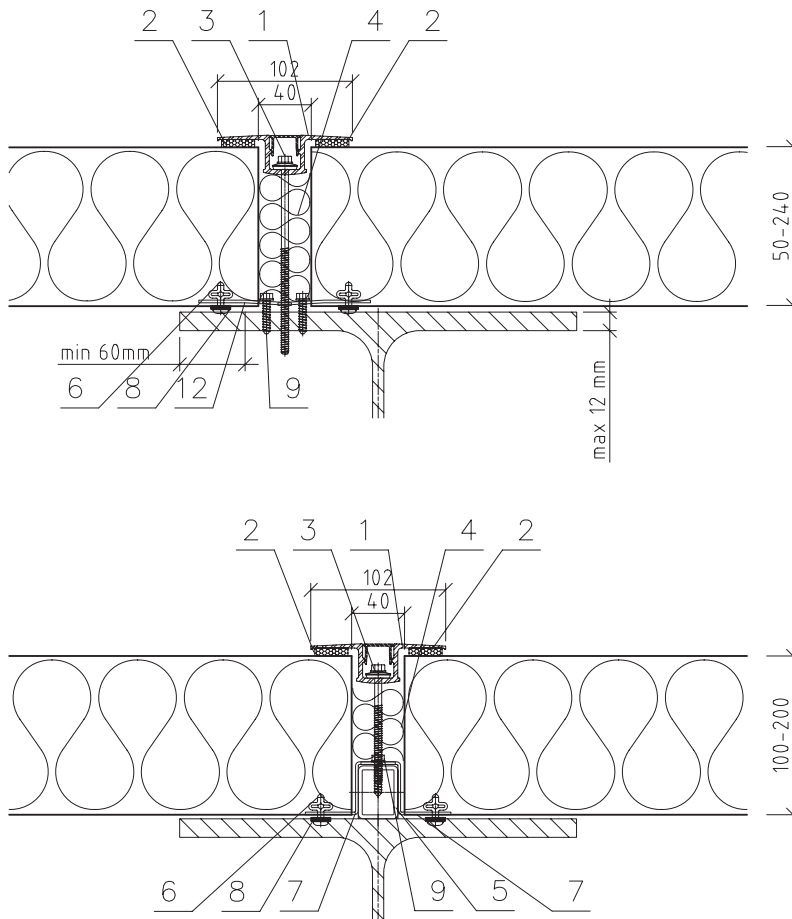

1. HF102 aluminium fixing profile
2. Sealing tape EPDM 6x25
3. Self-tapping screw
4. Thermal insulation
5. Rectangular steel tube 40x30x3
6. Bulb-tite rivet 5,2x19,1
7. Z profile
8. Sealing tape 3x15
9. Self-tapping screw 6,3x25
10. U profile
11. Z profile
12. Fixing plate

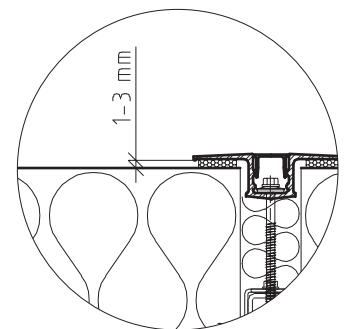

**NOTE:**

Distance between HF profile and Trimoterm panel needs to be 1 - 3 mm.

Fig. 12: HF102 aluminium fixing profile.

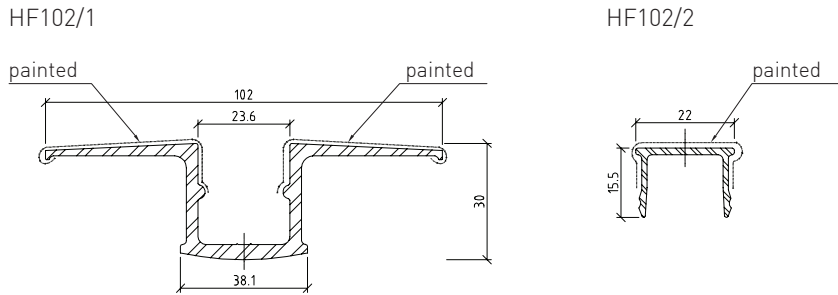

### 4.2.3 Temporary Fixing

The temporary fixing of panels when placing the panels to the horizontal façade should be fixed in the short term, to the hot-rolled steel profiles.

To accommodate this temporary fixing, profiles (Z profile) are inserted by pressing between the core and the inner steel sheet of the panel and then fixed with 2 4x8 mm stainless steel rivets (Fig. 13). Panels are installed correctly when the opening in the vertical joint is 40 mm. Panels are fixed to the sub-structure through temporary fixing profiles with self-tapping screws 6,3x25 as follows:

- in central area - 1 piece / panel,
- edge area, buildings with side openings - 2 pieces / panel,
- areas with wind loads higher than 0.5 KN/m<sup>2</sup> - 2 pieces / panel.

After the completed installation, each individual, vertical joint should be concealed by fixing a HF102 aluminium profile.

Fig. 13: Temporary mounting.

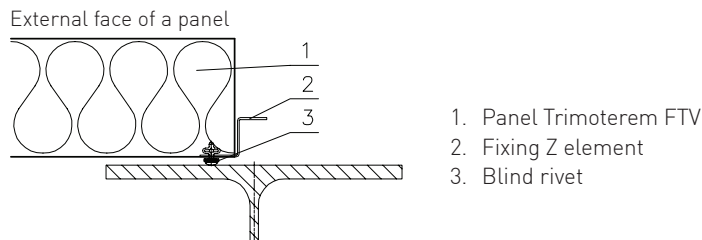
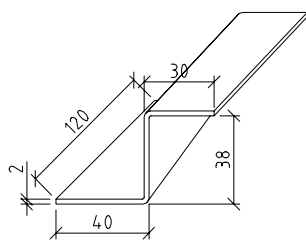
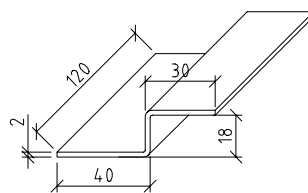

Fig. 14: Profiles types for temporary fixing (profile length: 120 mm)

a) FTV 100 - FTV 150



b) FTV 60 - FTV 80



c) For fixing without a distance profile (b < 12 mm)

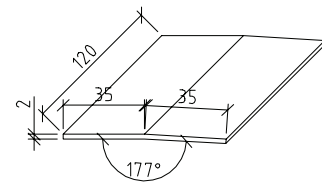

Fig. 15: Erection of a 100, 120, 150 and 200 mm thick panels

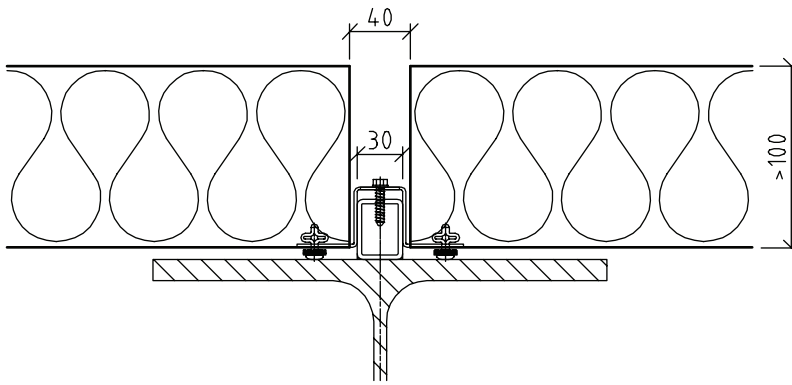

Fig. 16: Erection of panels in thickness types 60 and 80 mm

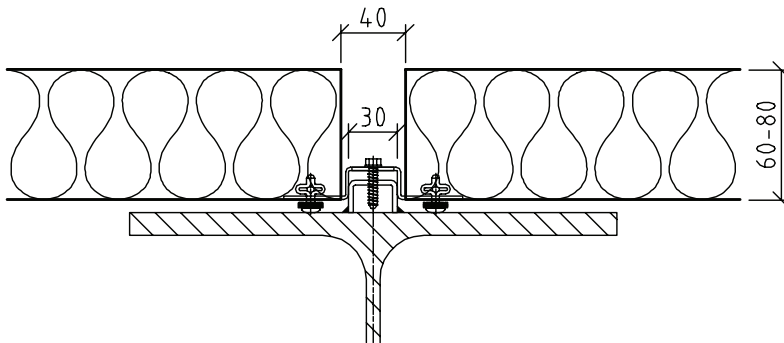
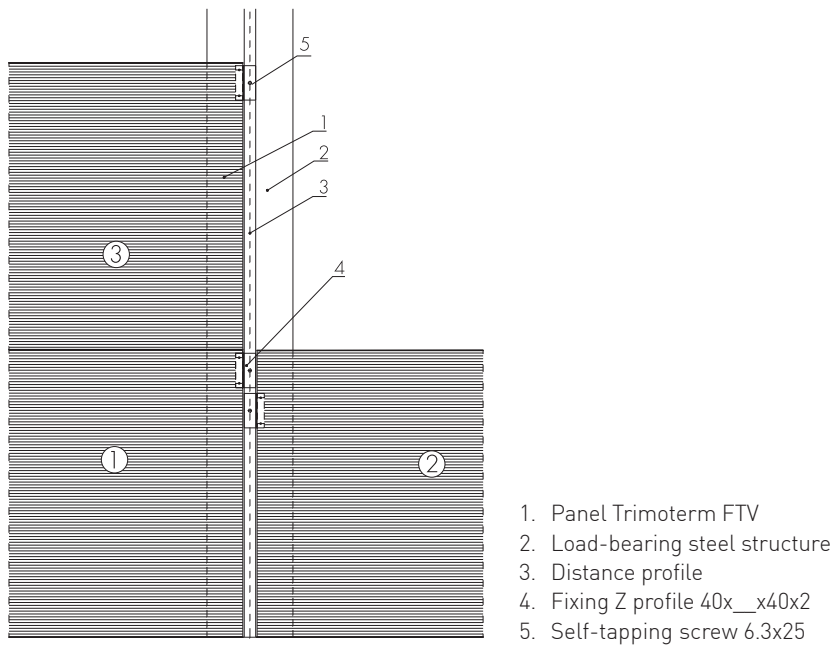

Fig. 17: Temporary mounting (1 piece / panel)



## 4.2.4 Assembly of Aluminium Profiles

### Assembly of HF102 Aluminium Fixing Profile

Sealing tape EPDM 6x25 (Fig. 18) should be applied to the HF102 aluminium fixing profile prior to installation. Please note that a seal must be applied to the profile edge.

Fig. 18: Position of sealing tape on the HF102 aluminium profile

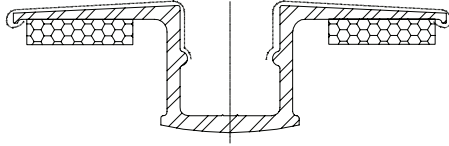

Cutting profiles to a required length, should be carried out by a suitable portable saw with a function that accommodates variable cutting angles. The deviation allowed is  $\pm 0.5$  mm at the width of 102 mm.

### Joining of HF102 aluminium fixing profiles

Fig. 19: Connecting aluminium element

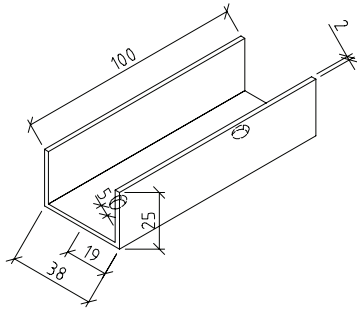
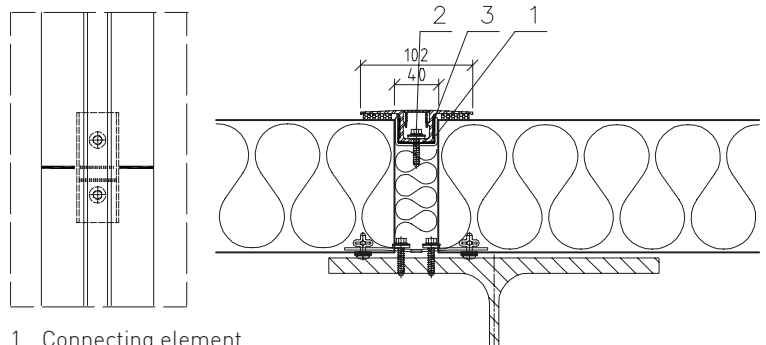

Fig. 20: Installation of a connecting element



1. Connecting element
2. Self-tapping screw 6.3x25
3. Mastic seal

Two profiles are joined by an additional connecting aluminium element (Fig. 19 and 22). The connecting element is fixed to the end of the HF102/1 aluminium profile by self-tapping screw TDB 6.3x25. The front side of the HF102 profile is sealed using polyurethane mastic seal (e.g. SIKAFLEX SF 221). Then the following HF102/1 aluminium fixing profile is inserted and the connecting profile is fixed to it. Before completing the final profile fixing, it is recommended that a short piece of HF102/2 profile be inserted in the joint of the HF102/1 profile for levelling; this short piece is fixed at least with a shift of 50 mm relating to the joint of HF102/1 profile.

## 4.3 Fixing a Horizontal Façade to a Concrete Structure

The concrete structure onto which panels are to be fixed should comply with ENV 13670-1 or/and Trimo internal requirements.

### 4.3.1 Fixing a Horizontal Façade by a Levelling Profile

Fig. 21: presents a fixing method by levelling the base. This method is useful for Trimoterm FTV panels of higher thickness (100, 120, 150, 200 and 240 mm). Dimensions of the levelling profile are presented in the Trimo standard details.

Fig. 21: Fixing a Trimoterm FTV panel horizontal façade using a levelling structure

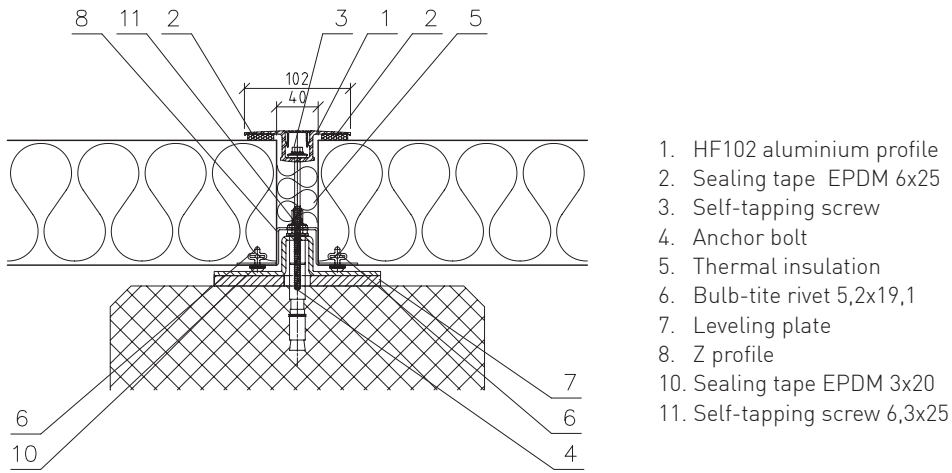

#### 4.3.2 Fixing a Horizontal Façade using Adjustable Substructure system HMP 2

The adjustable substructure system is used to level out the main structure of the building or supporting wall, in order to install the Trimoterm FTV façade system. Image 27 demonstrates the detail of adjustable substructure.

Fig. 22: Assembly mounting of Trimoterm FTV panels using a HMP 2

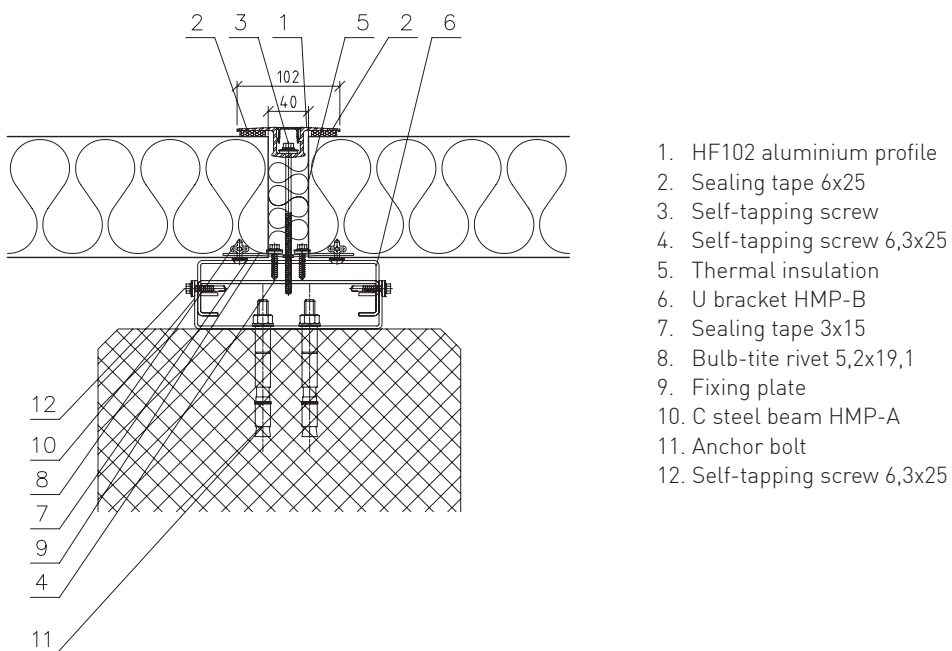

**NOTE:**

The following advice applies to fixing described in Sections 4.3.1 and 4.3.2:

- Suitable evenness of the overlying surface is assured by a levelling structure of a façade.
- Distances between anchor screws must be determined in accordance with a static calculation, relating to the properties of the building, wind loading, anchor type and the quality of the load-bearing structure.



**TRIMO D.O.O.**

PRIJATELJEVA CESTA 12,  
8210 TREBNJE, SLOVENIA

T: +386 (0)7 34 60 137

F: +386 (0)7 34 60 127

TRIMO@TRIMO-GROUP.COM

WWW.TRIMO-GROUP.COM

Trimo Group holds full copyrights on the information and details provided on this media, therefore any unauthorized reproduction and distribution is strictly prohibited. Professional care has been taken to ensure that information/details are accurate, correct and completed and not misleading, however Trimo, including its subsidiaries, does not accept responsibility or liability for errors or information, which is found to be misleading. Information/details on this media are for general purposes only. Use of it is on your own initiative and responsibility for compliance with local laws. Any deviations in details and project solutions are user responsibility. In no event, will we be liable for any loss or damage including without limitation, indirect or consequential loss or damage, or any loss or damage whatsoever arising from loss profits arising out of or in connection with, the use of this media. All information issued by Trimo Group is subject to continuous development and information/details contained on this media are current at date of issue. It is user's responsibility to obtain most up-to-date information from Trimo when information/details are used for project. The last version of the document is available on [www.trimo-group.com](http://www.trimo-group.com). Latest version of published document in English language prevails over other translated language documents. For information about the delivery of panels see Trimo's General conditions (<https://trimo-group.com/en/trimo/general-conditions-of-sale>).