

## **TECHNICAL MANUAL**

### **RITEDECK Through-colour Composite Decking**

#### **Product Description:**

Made in USA, RITEDECK timber composite decking by RITEDECK (Formerly called Rightwood Latitudes / Durodeck) has most of the attributes of timber with added advantages such as no maintenance, high durability and strength which provide a long-term aesthetically pleasing and cost effective outcome. Contributing to RITEDECK timber composite decking's outstanding physical properties, is the use of patented Strandex technology which offers superior thermal stability and increased UV resistance. This technology is the secret behind the success of this product in the most extreme Australian conditions.

#### **Sizing & Coverage:**

- 135 x 24mm Secret Fix Decking
- 135 x 24mm Pencil round Boards (For edge-boards, fascia and breaker boards)
- Coverage 7.14l/m per M2

#### **Storage Onsite:**

- RITEDECK composite cladding should be stored covered, flat and off the ground.
- Standard 5400mm long packs of RITEDECK require a minimum of eight gluts (supports) under the pack for proper storage.

#### **Accessories:**

- STOWAWAY Secret Fixing Clips
- BLACKHEAD 50mm x 7g secret fix timber screw
- BLACKHEAD 42mm x 7g secret fix metal screw
- COLOURFIX 65mm x 10g colour-matched timber screws
- COLOURFIX 40mm x 10g colour-matched metal screw
- RITEFRAME Steel Sub-framing Profiles
- RITEJACK Adjustable Decking Pedestals

#### **Important Information:**

The instructions in this brochure are for illustration purposes only and are not meant to replace a licensed professional. Any construction or use of the product must be in accordance with all local zoning and/or building codes. The consumer assumes all risks and liability associated with the construction or use of this product. The consumer or contractor should take all necessary steps to ensure the safety of everyone involved in the project, including, but not limited to, wearing the appropriate safety equipment. Except as contained in a written warranty, the supplier does not provide any other warranty, either express or implied, and shall not be liable for any damages, including consequential damages.

#### **Before You Start:**

As with any building project, installing RITEDECK turns out best when you think through the entire process in advance and familiarize yourself with the materials and their application. Please review the following tips before starting work on a RITEDECK project. Prior to construction, check with your local council for any special building requirements in your area. For best results, follow these simple installation instructions, paying close attention to gapping, spacing and fastener requirements. Also note any relevant information contained in the Blue Chip Group Pty Ltd terms of trading.

### Face Fixing With Screws:

We recommend using COLOURFIX colour-matched screws supplied by Blue Chip Group. Alternatively use 50x10g (24mm decking) and 65x14g (32mm decking) stainless steel square-drive screws. Always pre-drill and countersink prior to driving screws. Screws should be a minimum 20mm from the end or edge of the board and driven flush with the decking surface. Do not over-tighten. Use two fasteners per deck board at each joist. For any decking where two boards meet end-to-end over a joist, add additional blocking to the joist to support board ends.

### Joist Spans:

Maximum span is 450mm on-centre for 24mm decking in residential perpendicular applications. We recommend 400mm centres for commercial application or closer as required for structural engineering specifications.

### Spacing for Ventilation:

Allow 5-6mm distance between all decking material and any permanent structure or post. RITEDECK like all wood and composite decking products requires proper ventilation and drainage in order to ensure its longevity. There should be a 50mm clear space between the bottom edge of the joists and the finished ground level in order to allow for proper ventilation. Adequate drainage is also needed to prevent water pooling under the deck.

### Expansion, Contraction & Breaker Boards (See below):

All products with a plastic component will expand when temperatures increase, and this must be allowed for when planning a deck using composite material. Accordingly, we strongly recommend the use of Breaker boards on any deck longer than 6 metres to limit the expansion / contraction gaps to 6 mm. The traditional butt joining of boards is strongly advised against. The preferred method of deck design incorporates the use of breaker boards that are run across the deck at 90 degrees to the ends of the long boards so that the maximum gap possible is 6 mm. This gap can be halved if the board is fixed in the middle with the gap evenly distributed to either end of the board (see below regards locking screws). Additional joists/support is required in the substructure wherever a breaker board is being used. The breaker boards can be Face Fixed directly into the joists as above using COLOURFIX colour-matched screws.

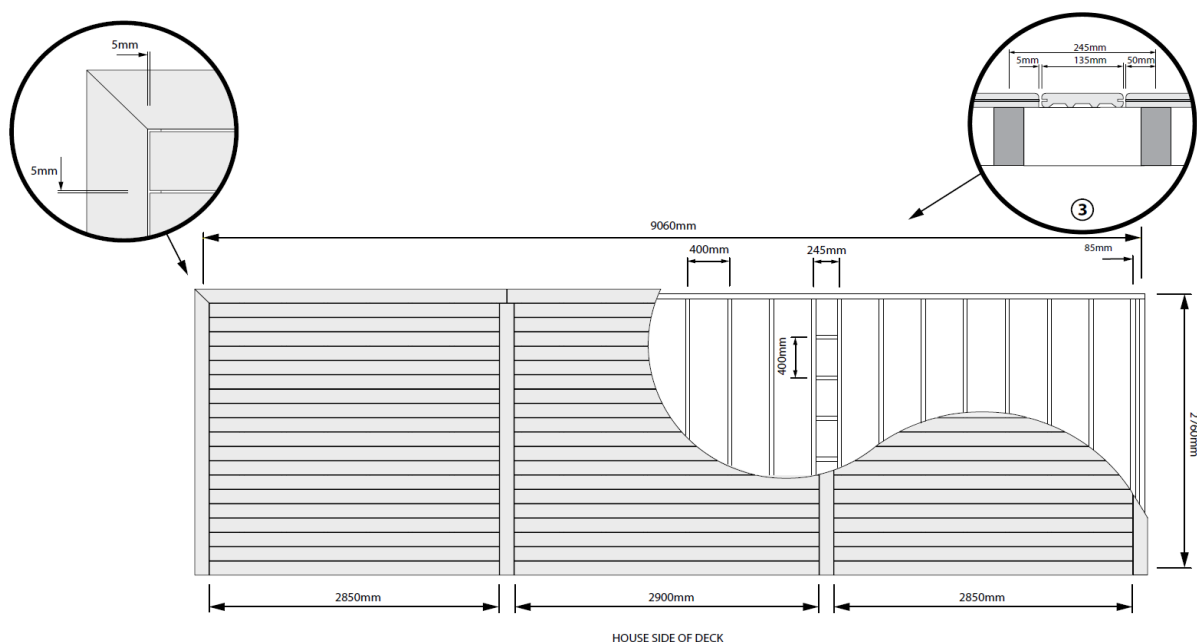

**End-to-End Spacing Between Boards:**

Allow minimum of 3mm gap between board ends for every 10°C of difference between installation temperature and the hottest temperature expected annually in the projects location (As per below table). Additional blocking to either side of the joist is recommended for support of butt joins.

		Warmest annual temperature °C expected in region												
		°C	-5	0	5	10	15	20	25	30	35	40	45	
Temperature °C on day of installation	-5		3mm	3mm	3mm	3mm	3mm	3mm	5mm	5mm	6mm	6mm	8mm	8mm
	0			3mm	3mm	3mm	3mm	3mm	3mm	5mm	5mm	6mm	6mm	8mm
	5				3mm	3mm	3mm	3mm	3mm	3mm	5mm	5mm	6mm	6mm
	10					3mm	3mm	3mm	3mm	3mm	3mm	5mm	5mm	6mm
	15						3mm	3mm	3mm	3mm	3mm	3mm	5mm	5mm
	20							3mm	3mm	3mm	3mm	3mm	3mm	5mm
	25								3mm	3mm	3mm	3mm	3mm	3mm
	30									3mm	3mm	3mm	3mm	3mm
	35										3mm	3mm	3mm	3mm
	40											3mm	3mm	3mm
	45												3mm	3mm

**Edge Board Installation - Horizontal Picture Frame Option:**

Cut the solid 135 x 24mm Pencil Round edge-boards to length, mitre as required for corners and then fasten the outside edge to the rim joist with COLOURFIX colour-matched screws. Although not critical, it is recommended to overhang the edge-board 24mm past the sub-frame to allow for running decking vertically down the sides of the deck as fascia boards if required.

**Edge Board Installation – Vertical Fascia Type Option:**

An alternative to using an edge-board is to use the same 135 x 24mm Pencil Round profile but as a fascia board on the side of the decking as opposed to the horizontal picture frame type option. Cut the solid 135 x 24mm Pencil Round edge-boards to length, mitre as required for corners and then fasten to the rim joist with COLOURFIX colour-matched screws. Overhang the boards 24mm above the top of the rim joist to allow for the thickness of the decking.

**Decking Installation:**

Install one secret-fixing clip at each joist location along the length of each decking board. For installations where deck boards are butted end-to-end at the joist, we recommend adding a 200mm blocking to either side of the joist and using a secret-fixing clip at the end of each board (Eg 4 clips per butt join). Be sure to gap the boards as previously described. Repeat the process for each board until the final board is cut to size to fit between the edge-board or building (leaving 5-6mm spacing) and fastened through the non-grooved edge with COLOURFIX colour-matched screws as described above.

**IMPORTANT: Do not overdrive screws into the STOWAWAY clips. Screws should be flush with the top off the clip and screw gun torque should be adjusted to low.**

\*\*\*See Next Page for pictures\*\*\*

### Locking Screws:

To keep the decking boards from moving over time, we recommend screwing the decking boards at the centre of their length using a 50x7g 'black-head' stainless steel screw diagonally through the side of the decking board. This holds the deck board in place at the centre of each board and allows the decking to expand/contract at the ends of the boards. Pre-drill in the slot of the deck board with a 3mm drill bit and drive screw into the slot so it's flush with the bottom of the groove. This will allow you to properly fit a STOWAWAY secret-fixing clip into the slot over the screw and centered over the joist.

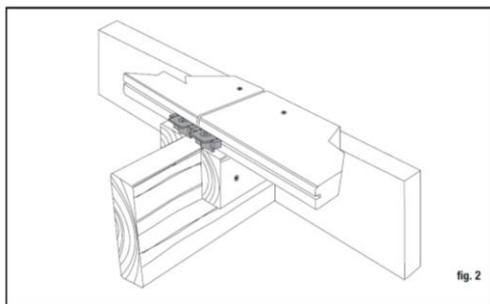

Final board against building.

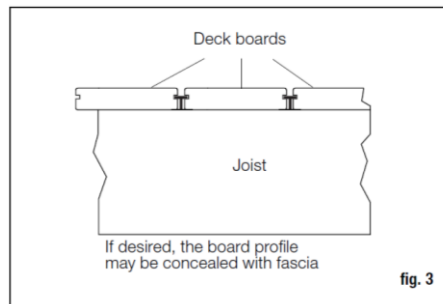

End-view of boards.

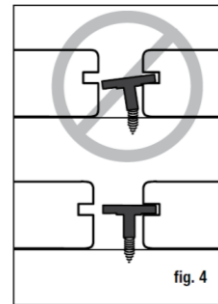

Clips to be level.

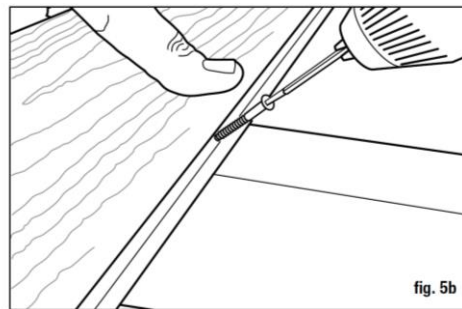
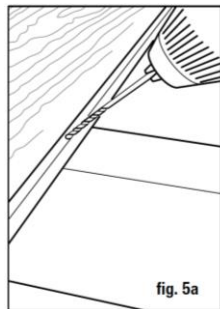

Pre-drill and insert diagonal locking screw in each board.

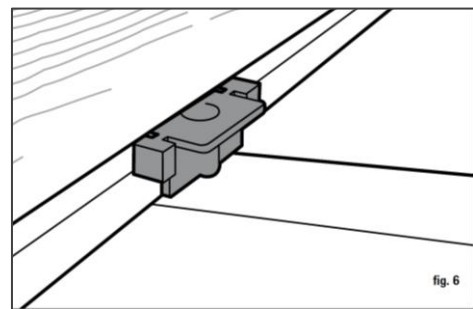

STOWAWAY clip at each joist.

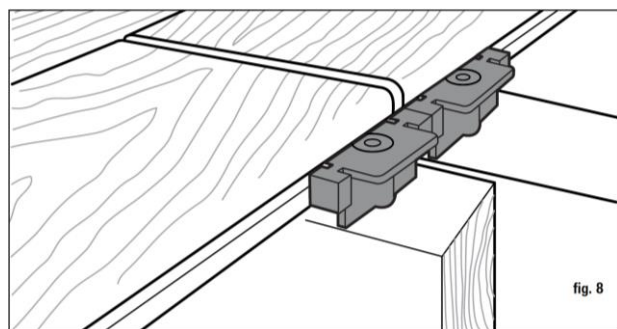
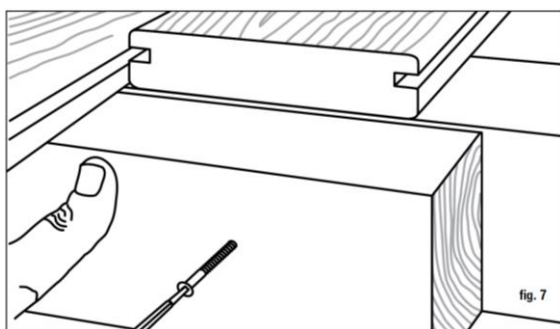

Additional blocking to be installed at all butt joints with a clip at the end of both boards.

### Finish Variation:

RITEDECK will lighten over time. This colour tone shift is dependent upon exposure to sunlight and other environmental factors and is generally completed within 60 to 90 days. Slight colour variation is not covered by the warranty. The appearance of this product will also change when viewed from different ends. To achieve the most consistent colour, install all of the boards in the same direction using the product end tags as a point of reference. Alternatively, to achieve subtle variation and possibly a more realistic appearance, install the boards in random directions to create contrasting light and dark shades of the deck board colour.

## **RITEDECK CLEANING & MAINTENANCE**

### **Low Maintenance:**

RITEDECK composite decking is virtually maintenance free, needing only periodic cleaning to keep it looking great however like any surface in your home RITEDECK looks best when the surface is kept clean. Normal cleaning is as simple as using a broom or mop with a mild detergent. Please read and follow these instructions to keep your decking looking its best.

### **Cleaning Recommendations:**

Periodic washing with soap / detergent and water will help remove surface dirt. This will also help prevent the build-up of pollen, debris and spores that can cause and accelerate mould / mildew growth. A pressure washer should not be used to “blast” mould / mildew or soils from a decking surface. The abrasive nature of the water stream can potentially damage the material by driving the spores into the material, which may create a more challenging problem to remediate. A pressure washer with a fan tipped nozzle should be used only to lightly wet or rinse wood or composite decking surfaces. There are many decking wash and exterior cleaning products available at retail stores. It is important to make sure you use a cleaner specifically intended for your application. After selecting a product, be certain to read, understand and follow all instructions supplied by the manufacturer. Some cleaning products and inhibitors may be more effective than others, depending on the environmental conditions your decking is subjected to. Additionally, it is always a good idea to test the cleaner in a small inconspicuous area prior to applying it to the entire decking.

### **Basic Cleaning Agents:**

Composite wash/ cleaners usually contain sodium per carbonate and a detergent, which is effective on normal dirt and grime and bleaches out mould and mildew stains. Oxalic acid cleaners are effective on rust stains from metal furniture. Commercial degreasers contain propylene glycol, sodium hydroxide, and various detergents for removing grease and oil stains. Spot removers/ thinners can be used sparingly on particularly stubborn grease or oil stains but should be washed off quickly with water as they will attack the grain pattern. These normally include petroleum distillates, xylene, methanol, acetone, or other organic solvents.

### **Mould & Mildew:**

Mould and mildew can be a nuisance on any exterior building surface, regardless of the material. If conditions are right they will spawn on wood, plastic, concrete, metal and other surfaces. Mould formation is most prevalent in wet, shaded areas. Spores from the natural environment are carried by the wind and commonly land on decking surfaces. It is important to note that the appearance of mould/mildew is a function of nature, not necessarily a deficiency with the decking material.

### **Inhibitors:**

As with decking washers, there are several mould inhibitor products available from paint stores, hardware stores, online outlets and home centres to help prevent long term mould/mildew growth. For any product selected, be certain to read, understand and follow all instructions supplied by the manufacturer. Depending on the environmental factors affecting your decking some preventative cleaning products may be more effective than others. It may be necessary to try more than one product. For ongoing preventative maintenance, follow the manufacturer’s recommendation.

### **Mould Removal:**

Mould may form on any surface where moisture is prevalent, where there is heavy shading, or where pollen and debris are allowed to collect. To eliminate mould, use conventional decking washers or cleaners that contain sodium percarbonate and detergent. These cleaners can be found at most home centres.

**Staining:**

RITEDECK resists accidental staining better than regular wood decking because it is a plastic and good composite however it is not stain-proof. Many stains can be removed with household cleaners and degreasers. Best results are achieved if you act quickly after staining occurs. Don't allow stains to penetrate the decking's surface or to bake on under direct sunlight. If you use a barbecue grill on your decking, keep a splatter guard underneath it; grills are a major source of grease stains and burns. To prevent water from pooling on the decking surface and staining it, make sure the decking boards have gaps between them to allow standing water to drain.

**Scratches:**

Just as wood decking materials can get scratched or gouged, the surface of RITEDECK can become scratched. We recommend allowing normal wear marks to fade, as they will blend in with the weathered colour. If the decking board does get scratched, you can use a wire brush and brush in the same direction as the original grain. In doing so, you will expose non-weathered decking and will experience a colour difference however this will weather in over time. Replace severely damaged pieces as you would with normal timber decking.

**Grime, Rust & Ground-in Dirt:**

In most cases, soap and water will maintain the appearance of RITEDECK products. If grime, ground-in dirt or rust marks become a problem, use a cleaning product with an oxalic acid base. Do not use bleach, abrasive cleansers or pads when cleaning.

**Timber Stains:**

RITEDECK requires only periodic cleaning with soap and water. Decking sealants are not recommended or required. While not recommended, RITEDECK can be stained after three months of exposure to various weather conditions. When staining RITEDECK ensure that the stain is intended for use on composite wood products. By choosing to stain RITEDECK, a relatively low-maintenance product changes to one that will require more upkeep. Always test a small, hidden portion of the decking before staining the entire decking. Durability of stain products varies by manufacturer. Exposure to ultraviolet light and surface traffic will also affect the stain's performance. Most manufacturers' literature indicates re-staining about every two years. Composite wood products do not accept paint or stain as well as wood; therefore, they will not have the same appearance as painted or stained wood.

**Other Important Information:**

As with any exposed exterior surface RITEDECK needs cleaning and maintenance to look its best and accordingly it is ultimately the clients responsibility to clean and maintain the product as required to maintain the desired performance and appearance. RITEDECK is not suitable for structural use. It should not be used for primary load bearing members such as posts, beams, joists or stringers. The same common sense precautions should be taken when handling as with wood or other building materials. Dust masks and eye protection are recommended to avoid possible irritation from sawdust and chips. Gloves will help to protect the hands. Hands should be washed after doing construction work. Always follow all safety precautions and instructions when using and cleaning or other chemical products. Any construction or use of the product must be carried out by a qualified installer in accordance with good commercial practice and any relevant codes or standards such as but not limited to local zoning and / or building codes. The consumer assumes all risks and liability associated with the construction or use of this product. The consumer or contractor should take all necessary steps to ensure the safety of everyone involved in the project, including, but not limited to, wearing the appropriate safety equipment. All information contained in the brochure and all sales and transactions are subject to Blue Chip Group Pty Ltd terms of trading which are available on request.